

Experiment no. 3

No-Load and Blocked Rotor Test on Three Phase Induction Motor

Aim of the Experiment:

1. To obtain the variation of no load power and current and blocked rotor power and current with changes in the applied voltage to the stator.
2. To determine the equivalent circuit parameters of an induction motor.

No load test:

THEORY:

The no load test is similar to the open circuit test on a transformer. It is performed to obtain the magnetizing branch parameters (shunt parameters) in the induction machine equivalent circuit. In this test, the motor is allowed to run with no-load at the rated voltage of rated frequency across its terminals. Machine will rotate at almost synchronous speed, which makes slip nearly equal to zero. This causes the equivalent rotor impedance to be very large (theoretically infinite neglecting the frictional and rotational losses). Therefore, the rotor equivalent impedance can be considered to be an open circuit which reduces the equivalent circuit diagram of the induction machine (Fig. 1) to the circuit as shown in Fig. 2. Hence, the data obtained from this test will give information on the stator and the magnetizing branch. The connection circuit diagram of no load test is shown in Fig. 3. The no load parameters can be found from the voltmeter, ammeter, and wattmeter readings obtained when the machine is run at no load as shown below:

Readings Obtained:

1. Line to line voltage at stator terminals : V_{nl} volts
2. Stator Phase Current : I_{nl} amps
3. Per phase power drawn by the stator : P_{nl} watts

Calculations:

$$Z_{nl} = \frac{(V_{nl} / \sqrt{3})}{I_{nl}} \text{ ohms}$$

$$r_{nl} = \frac{P_{nl}}{I_{nl}^2} = r_1 + r_c \text{ ohms}$$

$$X_{nl} = \sqrt{Z_{nl}^2 - R_{nl}^2} = X_1 + X_m \text{ ohms}$$

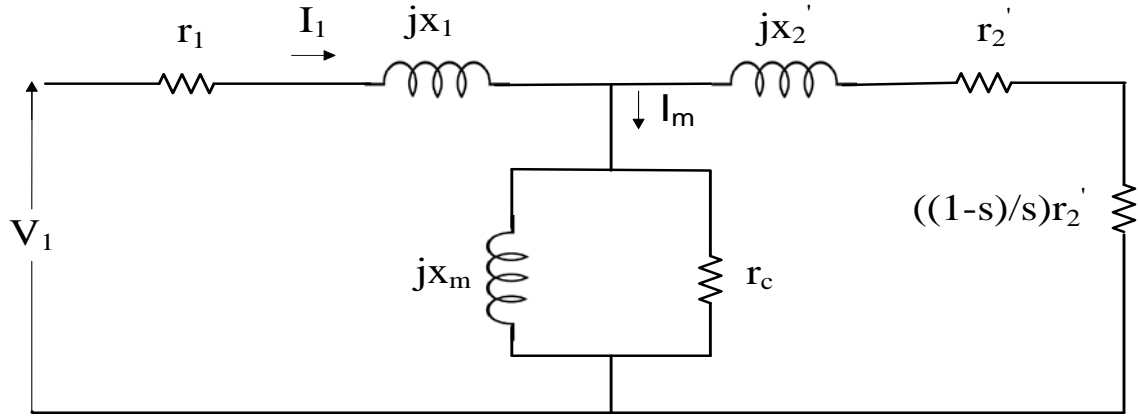

Fig. 1. Per phase equivalent circuit of 3-phase induction motor

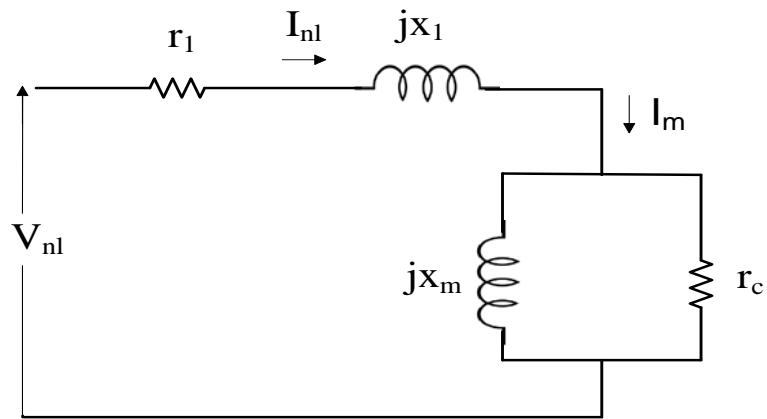

Fig. 2. Approximate Equivalent Circuit for No-Load Test

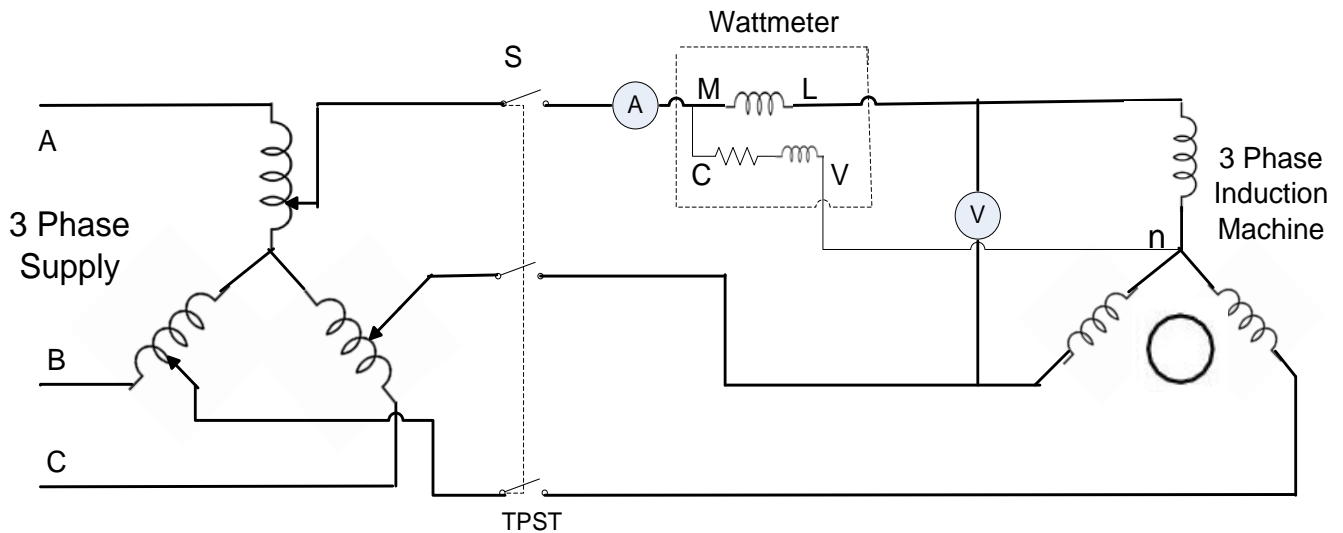

Fig. 3. Connection diagram for performing No-load and Blocked Rotor tests on 3 phase Induction machine

PROCEDURE:

1. Determine the meters and their ratings based on the name plate readings of the machine and requirement.
2. Connect the circuit as shown in Fig. 3.
3. Set/check the variac to be at zero output.
4. First switch on the 3 ϕ supply.
5. Close the TPST.
6. Gradually increase the voltage applied to the machine to the rated voltage. Motor runs at a speed quite close to its synchronous speed.
7. Take the reading of voltmeter, ammeter, wattmeter & speed on that particular voltage on the variac and make a table.

TABLE:

Sl no.	V_{nl}(volt)	I_{nl}(amp)	P_{nl}(watt)	N(rpm)

DISCUSSION:

1. What machine parameters can be obtained from No-Load test?
2. What is the power factor of the machine? Comment on its value.
3. What should be the no load current of an induction motor?
4. Even though there is no-load, why wattmeter reading is not zero?
5. Comment on the slip of the machine when operated at rated voltage.
6. How to obtain the no-load input power to an induction motor when two-wattmeter method of measuring power used?
7. Can a three phase induction motor be started from a single phase supply?
8. No load test is conducted at (a)rated current, (b)rated voltage, (c)high voltage, (d)high current
9. What is the nameplate reading on the machine? What inferences can be drawn from it?
10. What is the real and reactive power consumed in this test?
11. What are the different losses that are present in an induction machine?
12. Which loss in the machine is significant in no load test and why?

CONCLUSIONS:

Hence the parameters found :

Blocked rotor test:

THEORY: Blocked rotor test is similar to the short circuit test on a transformer. It is performed in the to calculate the series parameters of the induction machine i.e., its leakage impedances. The rotor is blocked to prevent rotation and balanced voltages are applied to the stator terminals at a frequency of 25 percent of the rated frequency at a voltage where the rated current is achieved. Under the reduced voltage condition and rated current, core loss and magnetizing component of the current are quite small percent of the total current, equivalent circuit reduces to the form shown in Fig. 4.

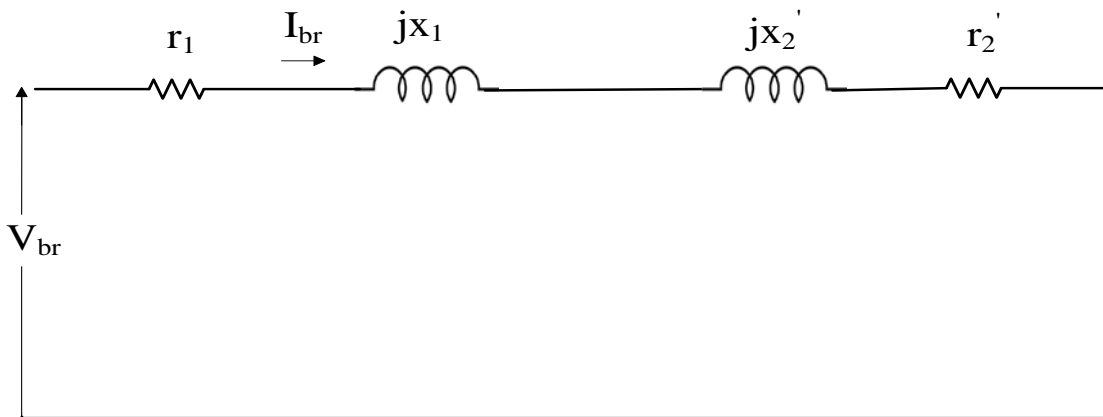

Fig. 4. Equivalent Circuit for Blocked Rotor Test

The slip for the blocked rotor test is unity since the rotor is stationary.

The resulting speed-dependent equivalent resistance $r_2' \{(1/s)-1\}$ goes to zero and the resistance of the rotor branch of the equivalent circuit becomes very small. Thus, the rotor current is much larger than current in the excitation branch of the circuit such that the excitation branch can be neglected. Voltage and power are measured at the motor input.

Readings Obtained:

Line to line voltage at stator terminals : V_{br} volts

Stator Phase Current : I_{br} amps

Per phase power drawn by the stator : P_{br} watts

Calculations:

$$Z_{br} = \frac{(V_{br} / \sqrt{3})}{I_{nl}} \text{ ohms}$$

$$r_{br} = \frac{P_{br}}{I_{br}^2} = r_1 + r_2' \text{ ohms}$$

$$X_{br} = \sqrt{Z_{br}^2 - R_{br}^2} = X_1 + X_2' \text{ ohms}$$

If it is assumed that $X_1 = X_2'$, then $X_1 = X_2' = \frac{X_{br}}{2}$ ohms

PROCEDURE:

1. Determine the meters and their ratings based on the name plate readings of the machine and requirement.
2. Connect the circuit as shown in Fig. 3.
3. **Set/check the variac to be at zero output.**
4. First switch on the 3 ϕ supply.
5. Close the TPST.
6. Now, keeping the rotor still (block the rotor from running), slowly increase the autotransformer output until rated current flows (Typically, this happens at 25% of the rated voltage).
7. Take the ammeter, voltmeter, and wattmeter readings and tabulate.
8. Repeat the procedure for other values stator phase current less than the rated value.

TABLE:

Sl no	I _{br} (Amps)	V _{br} (volt)	P _{br} (watt)

DISCUSSION:

1. Why block rotor test of an induction motor is carried out?
2. When r_2/s is split into a series connection of r_2' and $r_2' \{(1/s)-1\}$ in the rotor equivalent circuit of an induction machine, what do the power absorbed by the individual resistors physically represent?
3. How does the equivalent circuit of an induction motor simplify to under blocked rotor conditions? Justify.
4. What is the power factor of the machine?
5. Which loss in the machine is significant in blocked rotor test and why?

CONCLUSION:

Hence the parameters found: